



## Type PBL pressure relief valves

- Subplates with pressure relief valve face mounting cetop 3 (6-38) or 5 (10-12)

Technical specifications and diagrams are measured with mineral oil of 46 cSt viscosity at 40°C (104°F) temperature.

	<b>PBL 6/VMP 38</b>	<b>PBL 6/VMP 38/5Y</b>	<b>PBL 10/VMP 12</b>	
Nominal flow	35 l/min (9.2 US gpm)	35 l/min (9.2 US gpm)	60 l/min (16 US gpm)	
Max. pressure	Aluminium body = 210 bar (3050 psi) Steel body = 350 bar (5100 psi)			
Oil leakage at 80% of max. setting	3 cm <sup>3</sup> /min (0.18 in <sup>3</sup> /min)	1 cm <sup>3</sup> /min (0.06 in <sup>3</sup> /min)	5 cm <sup>3</sup> /min (0.30 in <sup>3</sup> /min)	
Fluid	mineral based oil			
Viscosity	from 10 to 200 cSt			
Max. level of contamination	18/16/13 ISO4406			
Fluid temperature	with NBR seals from -20°C (-4°F) to 80°C (176°F)			
Environmental temp. for working conditions	from -40°C (-40°F) to 100°C (212°F)			
Weight	aluminium	0.80 kg (1.76 lb)	0.80 kg (1.76 lb)	1.70 kg (3.75 lb)
	steel	1.98 kg (4.36 lb)	1.98 kg (4.36 lb)	4.29 kg (9.46 lb)

NOTE - For different conditions, please contact Walvoil Sales Dpt.

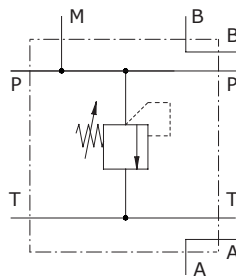

Dimensions

Valve type	P	T	A	B	M
PBL 6/VMP 38	G3/8				G1/4
PBL 6/VMP 38/5Y	G3/8				G1/4

Valve type	P	T	A	B	M
PBL 6/VMP 38/SAE	SAE8				SAE6

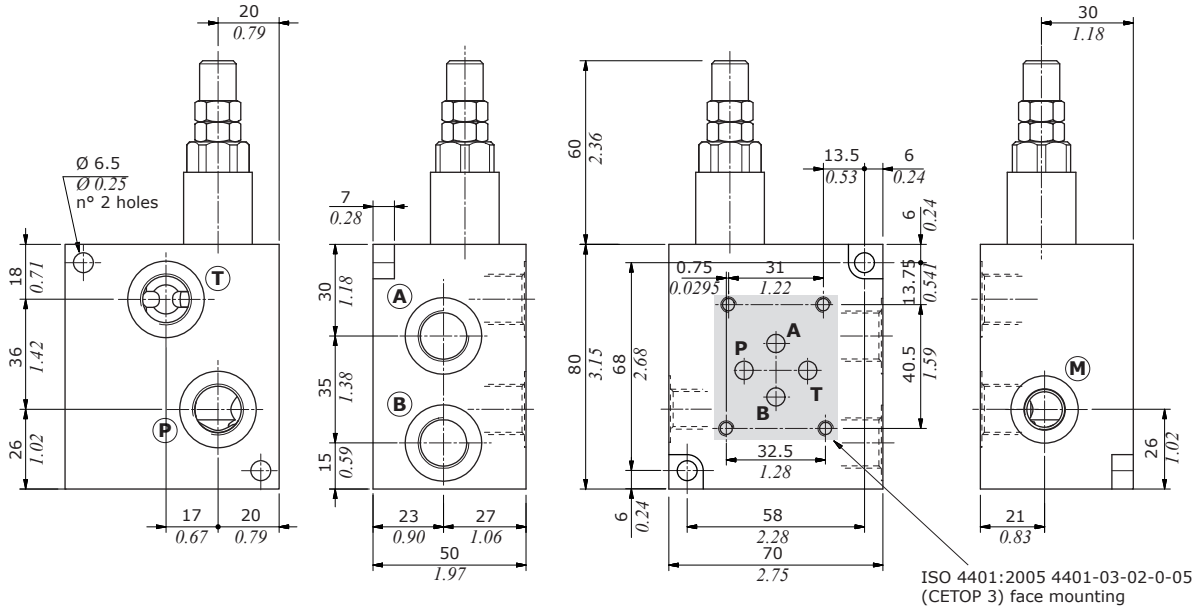

Valve type	P	T	A	B	M
PBL 10/VMP 12	G1/2				G1/4

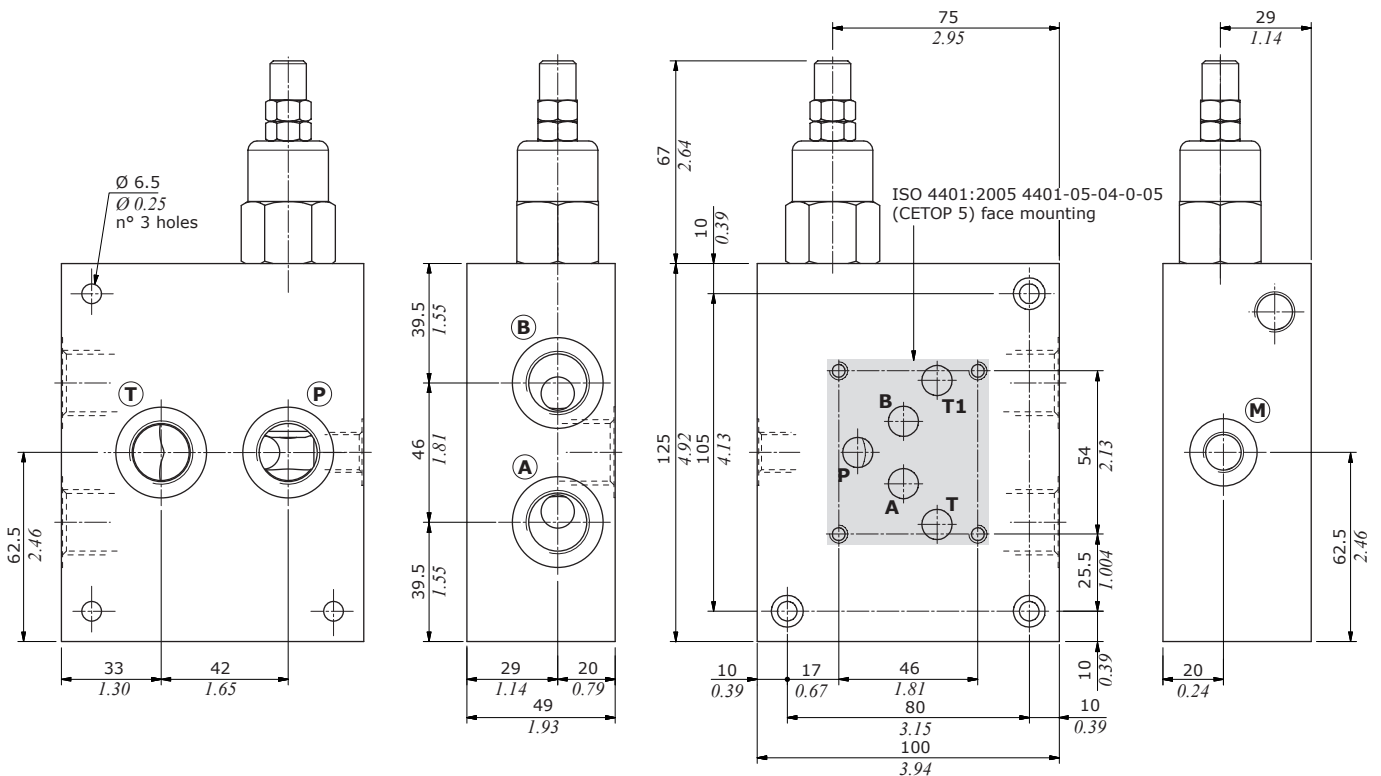

**Ordering codes and description composition**

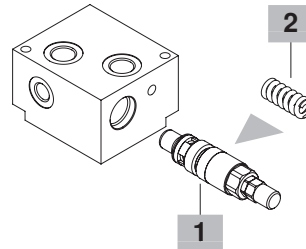
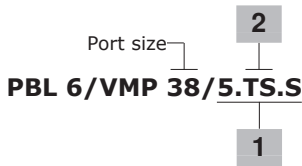

**PBL complete valves**

*With direct acting valves; standard setting is referred to 5 l/min (1.32 US gpm)*

**Configuration with G3/8 standard thread and ISO 4401:2005 4401-03-02-0-05 (CETOP 3) face mounting**

TYPE: **PBL 6/VMP 38/5.TS.S** CODE: 1114021102  
DESCRIPTION: Aluminium body, range 50-220 bar (725-3200 psi).  
Standard setting 160 bar (2300 psi)

TYPE: **PBL 6/VMP 38/5.TS.S/ac** CODE: 1114022101  
DESCRIPTION: Steel body, as previous one

TYPE: **PBL 6/VMP 38/5Y.TS.S** CODE: 1114021123  
DESCRIPTION: Aluminium body, range 140-190 bar (2030-2750 psi).  
Standard setting 150 bar (2200 psi)

**Configuration with G1/2 standard thread and ISO 4401:2005 4401-05-04-0-05 (CETOP 5) face mounting**

TYPE: **PBL 10/VMP 12/10.TS.S** CODE: 1114031102  
DESCRIPTION: Aluminium body, range 50-220 bar (725-3200 psi).  
Standard setting 160 bar (2300 psi)

TYPE: **PBL 10/VMP 12/10.TS.S/ac** CODE: 1114032101  
DESCRIPTION: Steel body, as previous one

**Configuration with SAE8 standard thread and ISO 4401:2005 4401-03-02-0-05 (CETOP 3) face mounting**

TYPE: **PBL 6/VMP 38/5.TS.S/SAE** CODE: 1114021200  
DESCRIPTION: Aluminium body, range 50-220 bar (725-3200 psi).  
Standard setting 160 bar (2300 psi)

For other steel body configurations, SAE thread and configurations with FPM (Viton) seals please contact our Sales Dpt.

**1 Direct acting pressure relief valves**

*Standard setting is referred to 5 l/min (1.32 US gpm)*

TYPE	CODE	DESCRIPTION
<b>For G3/8 and SAE8 ports configuration</b>		
<b>VMP 5/TS.S</b>	1100520400	Setting range 50-220 bar (725-3200 psi) Standard setting 160 bar (2300 psi)
<b>VMP 5Y/TS.S</b>	1100520406	Setting range 140-190 bar (2030-2755 psi) Standard setting 150 bar (2200 psi)

**For G1/2 ports configuration**

<b>VMP 10/TS.S</b>	1100530400	Setting range 50-220 bar (725-3200 psi)
--------------------	------------	---

**2 Pressure setting spring**

TYPE	CODE	DESCRIPTION
<b>For VMP 5 valve</b>		
<b>TB</b>	3MOL314311	Setting range 5-40 bar (72.5-580 psi)
<b>TV</b>	3MOL314330	Setting range 20-80 bar (290-1160 psi)
<b>TS</b>	3MOL315330	Setting range 50-220 bar (725-3200 psi)
<b>TR</b>	3ML1143600	Setting range 180-350 bar (2600-5100 psi)
<b>For VMP 5Y valve</b>		
<b>TB</b>	3MOL314311	Setting range 5-80 bar (72.5-1160 psi)
<b>TV</b>	3MOL314330	Setting range 40-150 bar (580-2200 psi)
<b>TS</b>	3ML1143400	Setting range 140-190 bar (2600-5100 psi)
<b>TR</b>	3MOL315330	Setting range 180-350 bar (2600-5100 psi)
<b>For VMP 10 valve</b>		
<b>TB</b>	3MOL316410	Setting range 5-40 bar (72.5-580 psi)
<b>TV</b>	3ML1154300	Setting range 20-80 bar (290-1160 psi)
<b>TS</b>	3MOL317420	Setting range 50-220 bar (725-3200 psi)
<b>TR</b>	3MOL317440	Setting range 180-350 bar (2600-5100 psi)

**Rating diagrams**

**PBL 6/VMP 38 pressure vs. flow**  
Std. setting @ 5 l/min (1.32 US gpm)

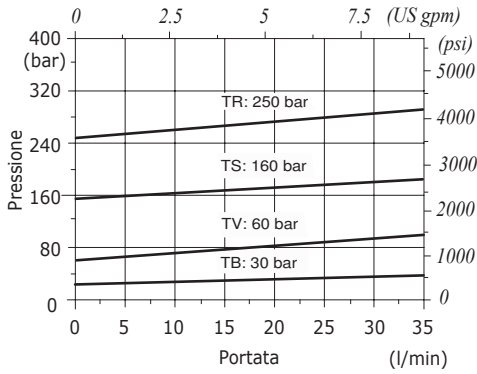

**PBL 6/VMP 38/5Y pressure vs. flow**  
Std. setting @ 5 l/min (1.32 US gpm)

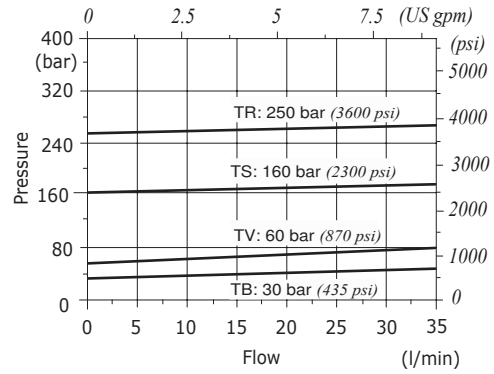

**PBL 10/VMP 12 pressure vs. flow**  
Std. setting @ 5 l/min (1.32 US gpm)

