



Type VRPRL-VRPRL/U pressure reducing valves

- With relieving

Technical specifications and diagrams are measured with mineral oil of 46 cSt viscosity at 40°C (104°F) temperature.

	VRPRL-VRPRL/U 38	VRPRL-VRPRL/U 12	
Nominal flow	20 l/min (5.3 US gpm)	50 l/min (13.2 US gpm)	
Max. pressure	Aluminium body = 210 bar (3050 psi) Steel body = 350 bar (5100 psi)		
Oil leakage	20 cm ³ /min at 150 bar (1.22 in ³ /min. at 2200 psi)		
Fluid	mineral based oil		
Viscosity	from 10 to 200 cSt		
Max. level of contamination	18/16/13 ISO4406		
Fluid temperature	with NBR seals from -20°C (-4°F) to 80°C (176°F)		
Environmental temp. for working conditions	from -40°C (-40°F) to 100°C (212°F)		
Weight	<i>aluminium</i>	0.83 kg (1.83 lb)	1.20 kg (2.64 lb)
	<i>steel</i>	1.75 kg (3.86 lb)	2.58 kg (5.69 lb)

NOTE - For different conditions, please contact Walvoil Sales Dpt.

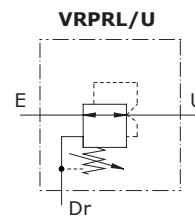
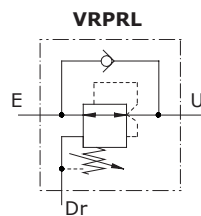

Dimensions

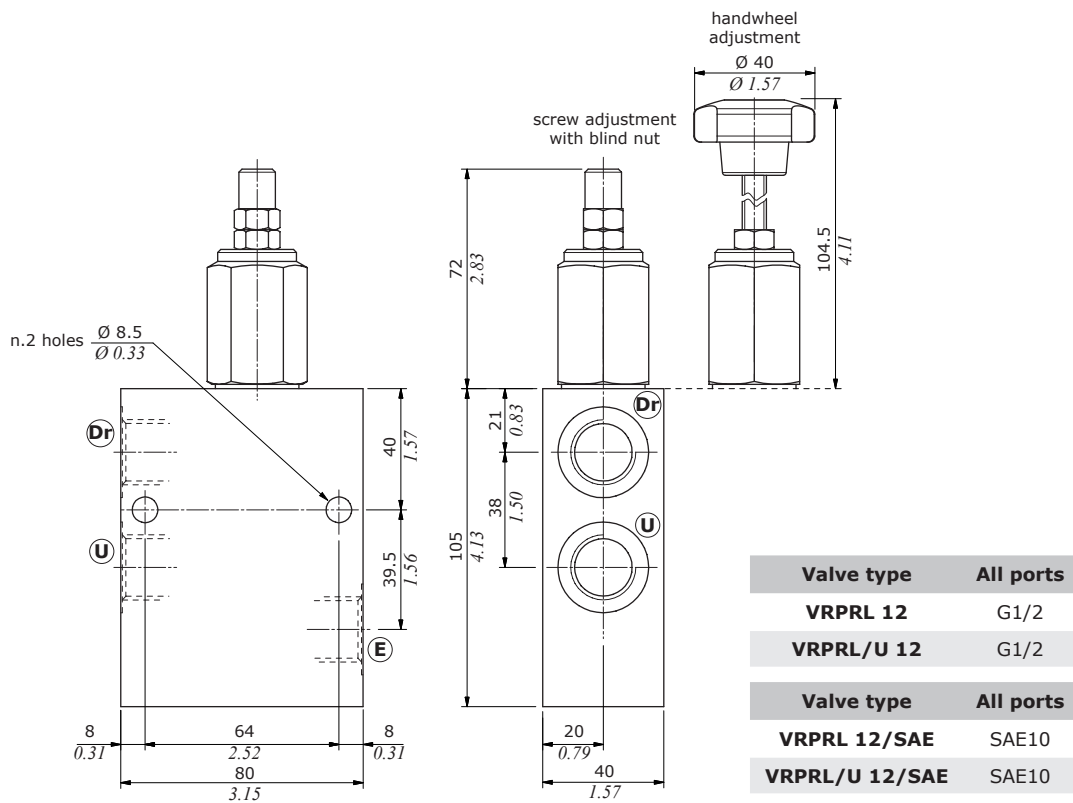
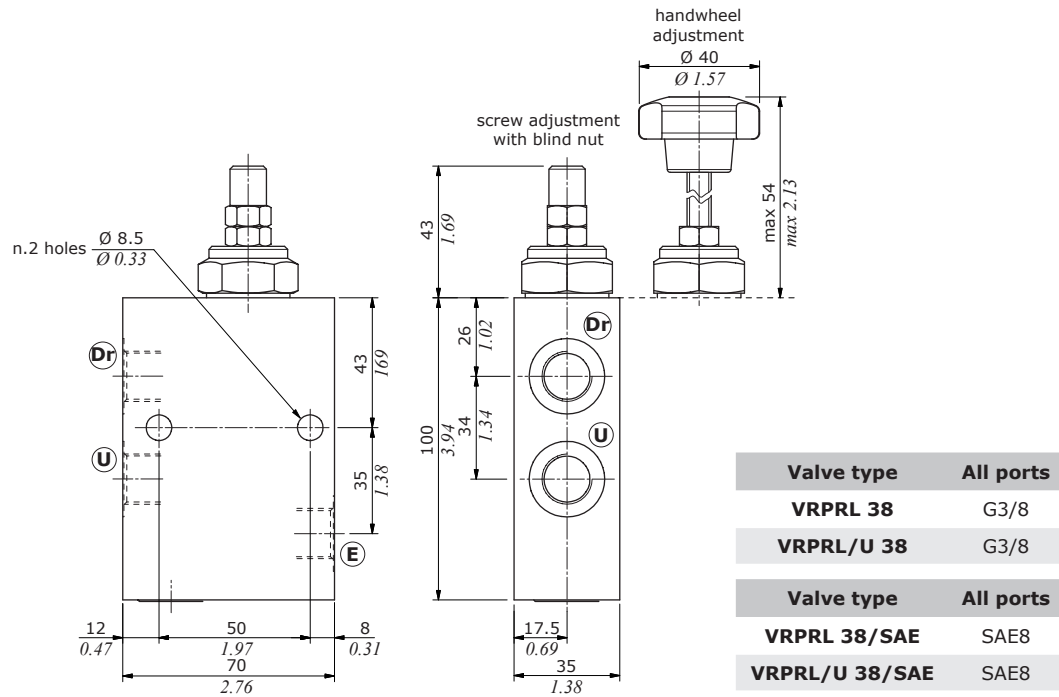

Ordering codes and description composition

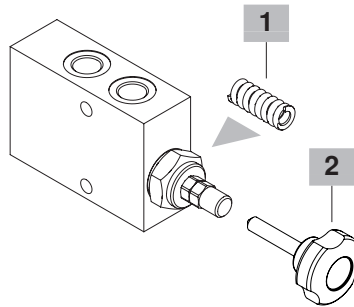
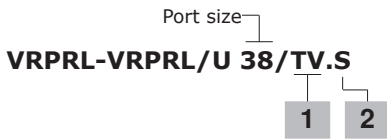

VRPRL-VRPRL/U complete valves

Valve configuration with reverse free flow check
Standard setting 90 bar @ 5 l/min (1300 psi @ 1.32 US gpm)

TYPE	CODE	DESCRIPTION
VRPRL 38/TV.S	1230021102	Aluminium body, setting range 40-110 bar (580-1600 psi)

VRPRL 38/TV.S/ac 1230022100 Steel body, as previous one

Configuration with G1/2 standard thread

VRPRL 12/TV.S	1230031102	Aluminium body, setting range 40-110 bar (580-1600 psi)
----------------------	------------	---

VRPRL 12/TV.S/ac 1230032100 Steel body, as previous one

Configuration with SAE8 standard thread

VRPRL 38/TV.S/SAE	1230021200	Aluminium body, setting range 40-110 bar (580-1600 psi)
--------------------------	------------	---

Configuration with SAE10 standard thread

VRPRL 12/TV.S/SAE	1230031200	Aluminium body, setting range 40-110 bar (580-1600 psi)
--------------------------	------------	---

Valve configuration with check valve

Standard setting 90 bar @ 5 l/min (1300 psi @ 1.32 US gpm)

TYPE	CODE	DESCRIPTION
VRPRL/U 38/TV.S	1233021102	Aluminium body, setting range 40-110 bar (580-1600 psi)

VRPRL/U 38/TV.S/ac 1233022100 Steel body, as previous one

Configuration with G1/2 standard thread

VRPRL/U 12/TV.S	1233031102	Aluminium body, setting range 40-110 bar (580-1600 psi)
------------------------	------------	---

VRPRL/U 12/TV.S/ac 1233032102 Steel body, as previous one

Configuration with SAE8 standard thread

VRPRL/U 38/TV.S/SAE	1233021201	Aluminium body, setting range 40-110 bar (580-1600 psi)
----------------------------	------------	---

Configuration with SAE10 standard thread

VRPRL/U 12/TV.S/SAE	1233031105	Aluminium body, setting range 40-110 bar (580-1600 psi)
----------------------------	------------	---

For other steel body configurations, SAE thread and configurations with FPM (Viton) seals please contact our Sales Dpt.

1 Pressure setting spring

TYPE	CODE	DESCRIPTION
For VRPRL 38 valve		
TB	3ML1133100	Setting range 5-50 bar (72.5-725 psi)
TV	3MOL314330	Setting range 40-110 bar (580-1600 psi)
TS	3MOL315330	Setting range 100-200 bar (1450-2900 psi)
For VRPRL 12 valve		
TB	3ML1166804	Setting range 5-50 bar (72.5-725 psi)
TV	3ML1146800	Setting range 40-110 bar (580-1600 psi)
TS	3ML1166805	Setting range 100-200 bar (1450-2900 psi)

2 Accessories

TYPE	CODE	DESCRIPTION
V	4VL2407100	Handwheel

Rating diagrams

VRPRL-VRPRL/U 38

Relieving diagram from U to Dr Pressure vs. Flow from E to U

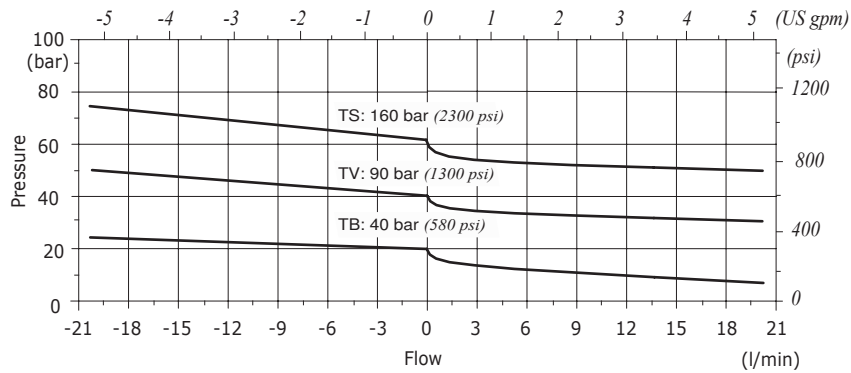

VRPRL-VRPRL/U 12

Relieving diagram from U to Dr Pressure vs. Flow from E to U

