



Type VOSLP counterbalance valves

- Single acting

Technical specifications and diagrams are measured with mineral oil of 46 cSt viscosity at 40°C (104°F) temperature.

	VOSLP 38	VOSLP 12	VOSLP 34	VOSLP 100	
Nominal flow	35 l/min (9.2 US gpm)	70 l/min (18.5 US gpm)	100 l/min (26.4 US gpm)	180 l/min (47.6 US gpm)	
Max. pressure	Aluminium body = 210 bar (3050 psi) Steel body = 350 bar (5100 psi)				
Oil leakage	0.25 cm ³ /min - 0.015 in ³ /min. (5 drops) at 210 bar - 3050 psi at 80% of pressure setting				
Fluid	mineral based oil				
Viscosity	from 10 to 200 cSt				
Max. level of contamination	18/16/13 ISO4406				
Fluid temperature	with NBR seals from -20°C (-4°F) to 80°C (176°F)				
Environmental temp. for working conditions	from -40°C (-40°F) to 100°C (212°F)				
Weight	<i>aluminium</i>	0.89 kg (1.96 lb)	0.97 kg (2.14 lb)	1.75 kg (3.86 lb)	2.90 kg (6.39 lb)
	<i>steel</i>	1.59 kg (3.51 lb)	1.88 kg (4.14 lb)	3.29 kg (7.25 lb)	6.18 kg (13.6 lb)

NOTE - For different conditions, please contact Walvoil Sales Dpt.

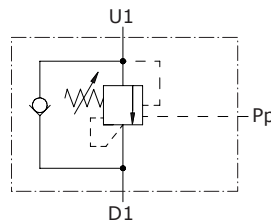

Dimensions

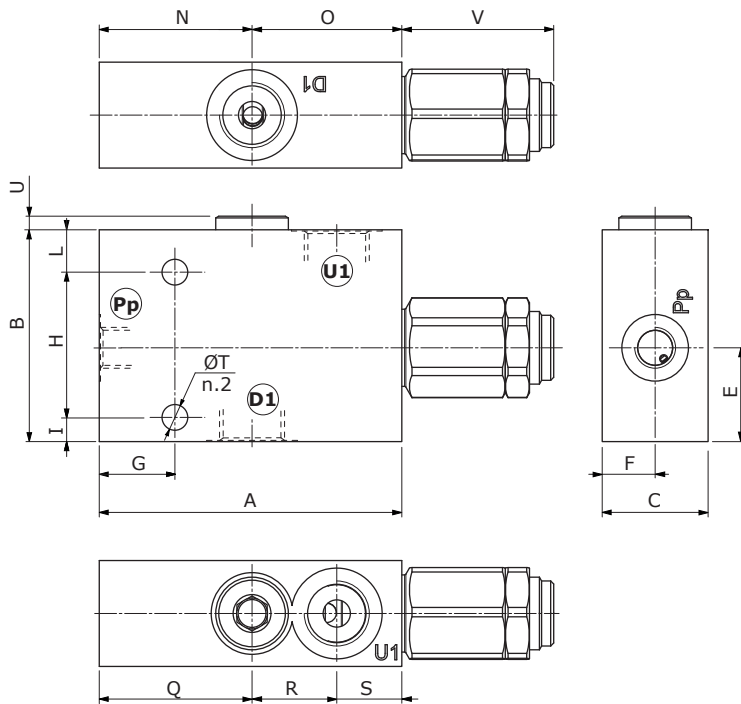

Valve type	D1	U1	Pp
VOSLP 38	G3/8	G1/4	G1/4
VOSLP 12	G1/2	G1/4	G1/4
VOSLP 34	G3/4	G1/4	G1/4
VOSLP 100	G1"	G1/4	G1/4

Dimensions are in mm-in

Valve type	A	B	C	E	F	G	H	I	L	N	O	Q	R	S	ØT	V
VOSLP 38	98 3.86	65 2.56	30 1.18	27 1.06	15 0.59	27 1.06	40 1.57	8 0.315	17 0.70	47 1.85	51 2.01	47 1.85	29 1.14	22 0.87	8.5 0.335	52 2.05
VOSLP 12	100 3.94	70 2.76	35 1.38	31 1.22	17.5 0.69	25 0.98	48 1.89	8 0.315	14 0.551	50.5 1.99	49.5 1.95	50.5 1.99	28 1.10	21.5 0.85	8.5 0.335	57 2.24
VOSLP 34	120 4.72	90 3.54	40 1.57	36 1.42	20 0.79	32 1.26	70 2.76	10 0.394	10 0.394	55 2.16	65 2.56	55 2.17	35 1.38	30 1.18	10.5 0.41	66 2.60
VOSLP 100	140 5.51	100 3.94	60 2.36	37 1.46	30 1.18	30 1.18	80 3.15	10 0.394	10 0.394	64 2.52	76 2.99	64 2.52	46 1.81	30 1.18	10.5 0.41	66 2.60

Ordering codes

VOSLP complete valves

TYPE: **VOSLP 38/TR.S.p4** CODE: 1530021102

DESCRIPTION: Aluminium body, G3/8 ports, pilot ratio 1:4, range 50-350 bar (725-5075 psi), std setting 280 bar (4060 psi) @ 5 l/min (1.32 US gpm)

TYPE: **VOSLP 12/TR.S.p7** CODE: 1530031102

DESCRIPTION: Aluminium body, G1/2 ports, pilot ratio 1:7, range 50-350 bar (725-5075 psi), std setting 280 bar (4060 psi) @ 5 l/min (1.32 US gpm)

TYPE: **VOSLP 34/TR.S.p7** CODE: 1530041102

DESCRIPTION: Aluminium body, G3/4 ports, pilot ratio 1:7, range 50-350 bar (725-5075 psi), std setting 280 bar (4060 psi) @ 5 l/min (1.32 US gpm)

TYPE: **VOSLP 100/TR.S.p7** CODE: 1530051102

DESCRIPTION: Aluminium body, G1" ports, pilot ratio 1:7, range 50-350 bar (725-5075 psi), std setting 280 bar (4060 psi) @ 5 l/min (1.32 US gpm)

For other configurations and steel body, please contact our Sales Dept.

VOSLP 38 pressure drop vs. flow from D1->U1 and U1->D1

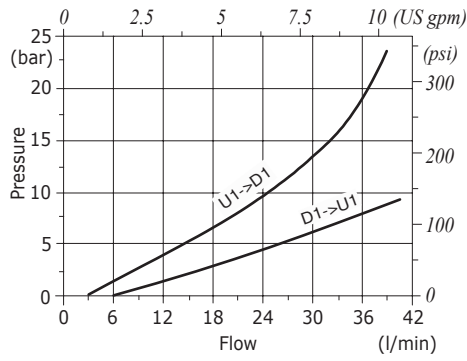

VOSLP 12 pressure drop vs. flow from D1->U1 and U1->D1

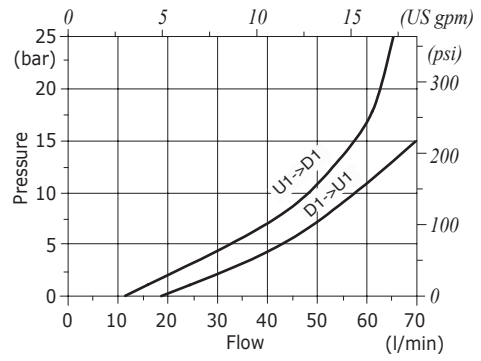

VOSLP 34 pressure drop vs. flow from D1->U1 and U1->D1

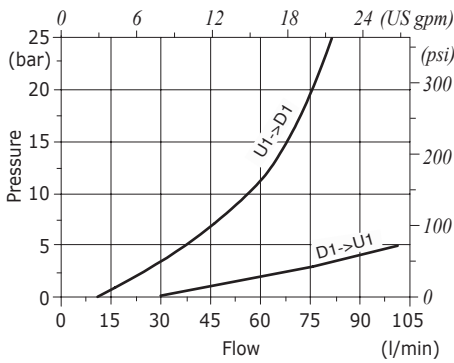

VOSLP 100 pressure drop vs. flow from D1->U1 and U1->D1

