



Type VOSL/ML counterbalance valves

- Single acting
- Load sensitive
- Flange assembling according to ISO 4401:2005 (CETOP)

Technical specifications and diagrams are measured with mineral oil of 46 cSt viscosity at 40°C (104°F) temperature.

	VOSL/ML 6-38	VOSL/ML 10-12
Nominal flow	35 l/min (9.2 US gpm)	70 l/min (18.5 US gpm)
Max. pressure	Aluminium body = 210 bar (3050 psi) Steel body = 350 bar (5100 psi)	
Oil leakage	0.25 cm ³ /min - 0.015 in ³ /min. (5 drops) at 210 bar - 3050 psi at 80% of pressure setting	
Fluid	mineral based oil	
Viscosity	from 10 to 200 cSt	
Max. level of contamination	18/16/13 ISO4406	
Fluid temperature	with NBR seals from -20°C (-4°F) to 80°C (176°F)	
Environmental temp. for working conditions	from -40°C (-40°F) to 100°C (212°F)	
Weight	aluminium	1.27 kg (2.80 lb)
	steel	2.68 kg (5.91 lb)
		2.27 kg (5.00 lb)
		5.46 kg (12.04 lb)

NOTE - For different conditions, please contact Walvoil Sales Dpt.

VOSL/ML 6-38A

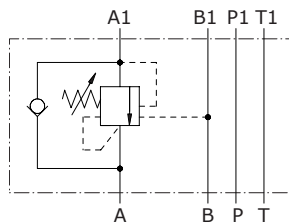

VOSL/ML 10-12A

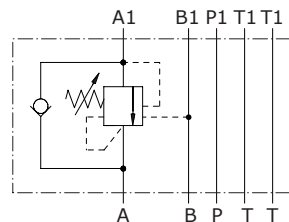

VOSL/ML 6-38B

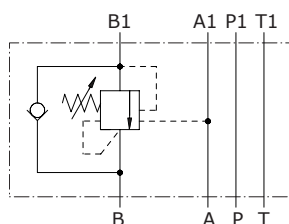

VOSL/ML 10-12B

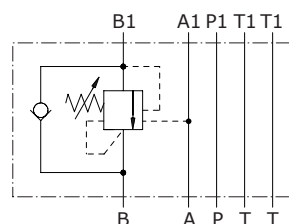

Dimensions

VOSL/ML 6-38A

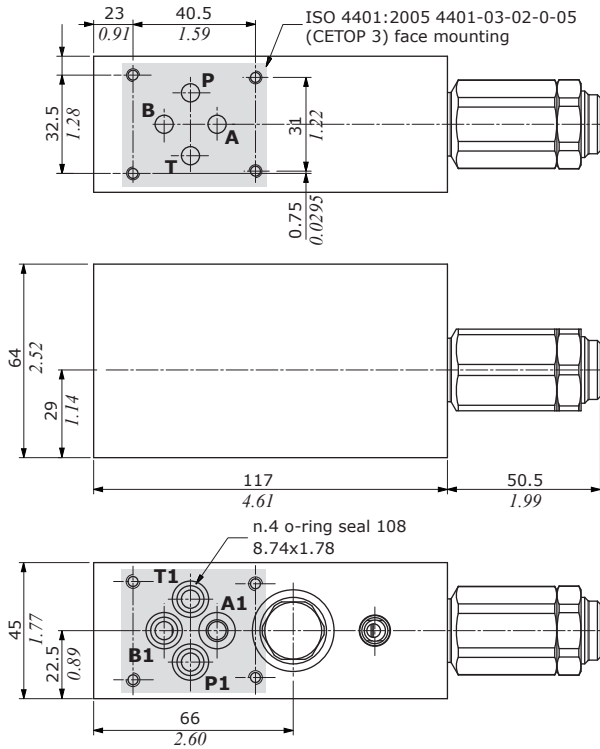

VOSL/ML 10-12A

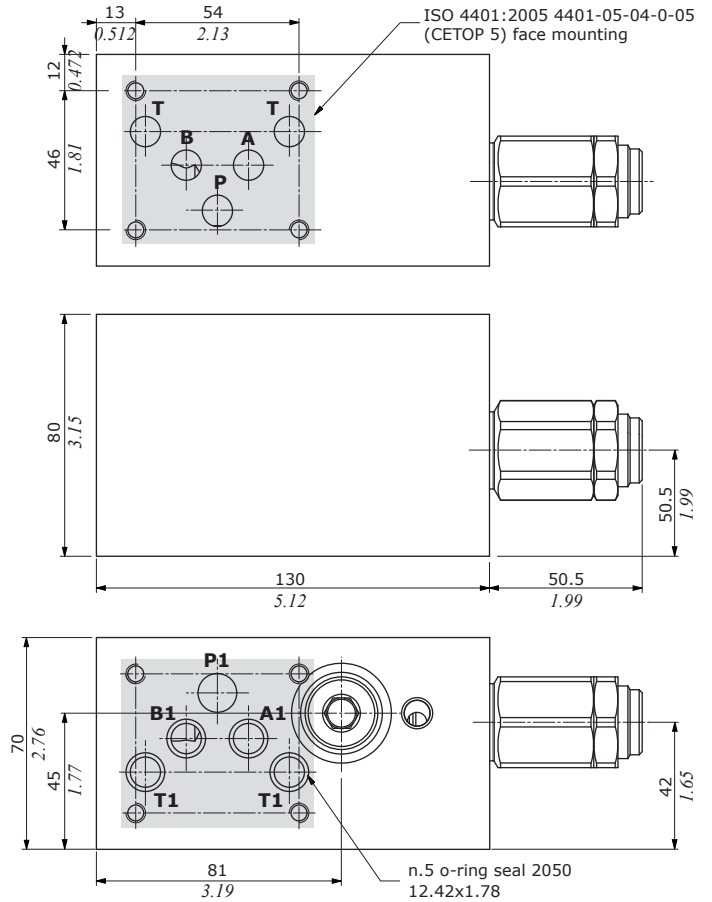

VOSL/ML 6-38B

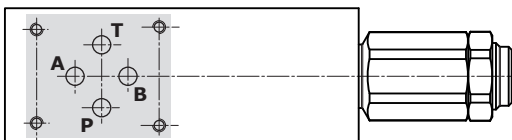

VOSL/ML 10-12B

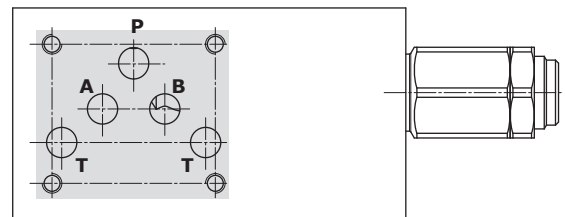

Ordering codes

VOSL/ML complete valves

- TYPE: **VOSL/ML 6-38A/TR.S.p4** CODE: 1518021802
 DESCRIPTION: Aluminium body, CETOP 3 flange, pilot ratio 1:4, range 50-350 bar (725-5075 psi), std setting 280 bar (4060 psi) @ 5 l/min (1.32 US gpm)
- TYPE: **VOSL/ML 6-38B/TR.S.p4** CODE: 1518021808
 DESCRIPTION: Aluminium body, CETOP 3 flange, pilot ratio 1:4, range 50-350 bar (725-5075 psi), std setting 280 bar (4060 psi) @ 5 l/min (1.32 US gpm)
- TYPE: **VOSL/ML 10-12A/TR.S.p7.PG** CODE: 1518031802
 DESCRIPTION: Aluminium body, CETOP 5 flange, pilot ratio 1:7, range 50-350 bar (725-5075 psi), std setting 280 bar (4060 psi) @ 5 l/min (1.32 US gpm)
- TYPE: **VOSL/ML 10-12B/TR.S.p7.PG** CODE: 1518031808
 DESCRIPTION: Aluminium body, CETOP 5 flange, pilot ratio 1:7, range 50-350 bar (725-5075 psi), std setting 280 bar (4060 psi) @ 5 l/min (1.32 US gpm)
- For other configurations and steel body, please contact our Sales Dept.

VOSL/ML 6-38 pressure drop vs. flow from A->A1 (B1->B) and A1->A (B1->B)

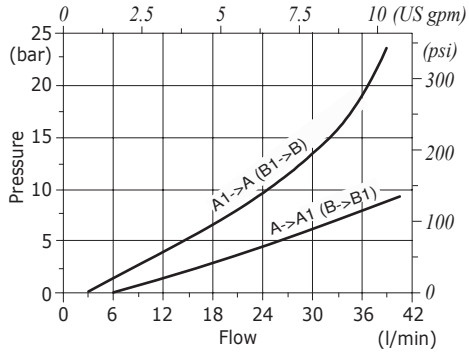

VOSL/ML 10-12 pressure drop vs. flow from A->A1 (B->B1) and A1->A (B1->B)

