



Type VDA unloader valves

- Single acting
- Built-in check

Technical specifications and diagrams are measured with mineral oil of 46 cSt viscosity at 40°C (104°F) temperature.

	VDA 38	VDA 12	VDA 34
Nominal flow	25 l/min (6.6 US gpm)	50 l/min (13.2 US gpm)	100 l/min (26.4 US gpm)
Max. pressure		Aluminium body = 210 bar (3050 psi) Steel body = 350 bar (5100 psi)	
Fluid		mineral based oil	
Viscosity		from 10 to 200 cSt	
Max. level of contamination		18/16/13 ISO4406	
Fluid temperature		with NBR seals from -20°C (-4°F) to 80°C (176°F)	
Environmental temp. for working conditions		from -40°C (-40°F) to 100°C (212°F)	
Weight	aluminium	2.15 kg (4.73 lb)	3.24 kg (7.14 lb)
	steel	5.05 kg (12.13 lb)	8.10 kg (17.86 lb)

NOTE - For different conditions, please contact Walvoil Sales Dpt.

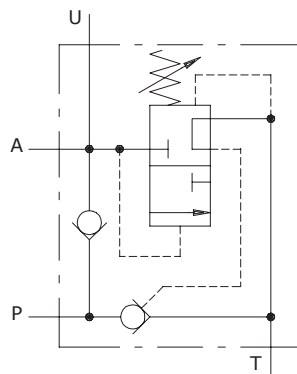

Dimensions

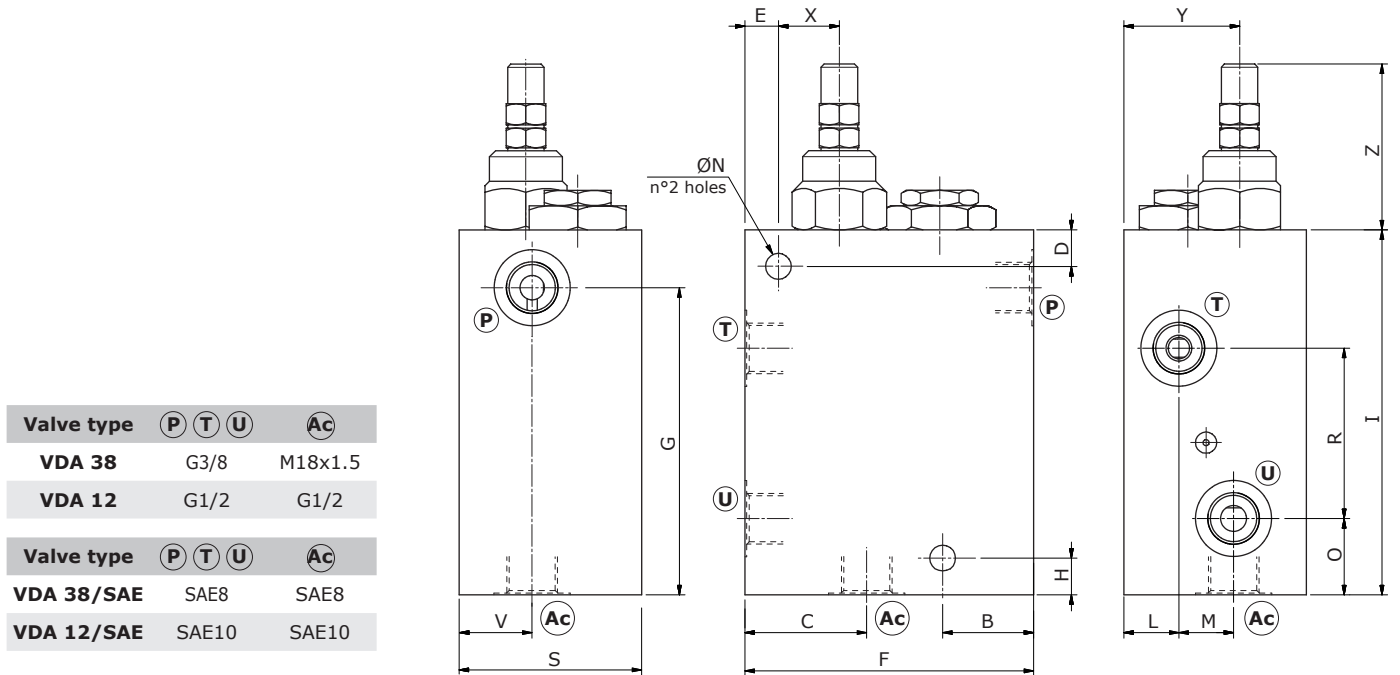

Valve type	P	T	U	Ac
VDA 38	G3/8			M18x1.5
VDA 12	G1/2			G1/2
Valve type	P	T	U	Ac
VDA 38/SAE	SAE8			SAE8
VDA 12/SAE	SAE10			SAE10

Dimensions are in mm-in

Valve type	B	C	D	E	F	G	H	I	L	M	ØN	O	R	S	V	X	Y	Z
VDA 38	30-1.18	40-1.57	12-0.47	11-0.43	95-3.74	101-3.98	12-0.47	120-4.72	18-0.71	18-0.71	8.5-0.33	25-0.98	56-2.20	60-2.36	24-0.94	20-0.79	38-1.50	56-2.20
VDA 12	42-1.65	42-1.65	13-0.51	12-0.47	108-4.25	101-3.98	11-0.43	120-4.72	19-0.75	11-0.43	8.5-0.33	25-0.98	56-2.20	60-2.36	23-0.91	22-0.87	38-1.50	56-2.20

Valve type	P	T	U	Ac
VDA 34	G3/4			G1/2
Valve type	P	T	U	Ac
VDA 34/SAE	SAE12			SAE10

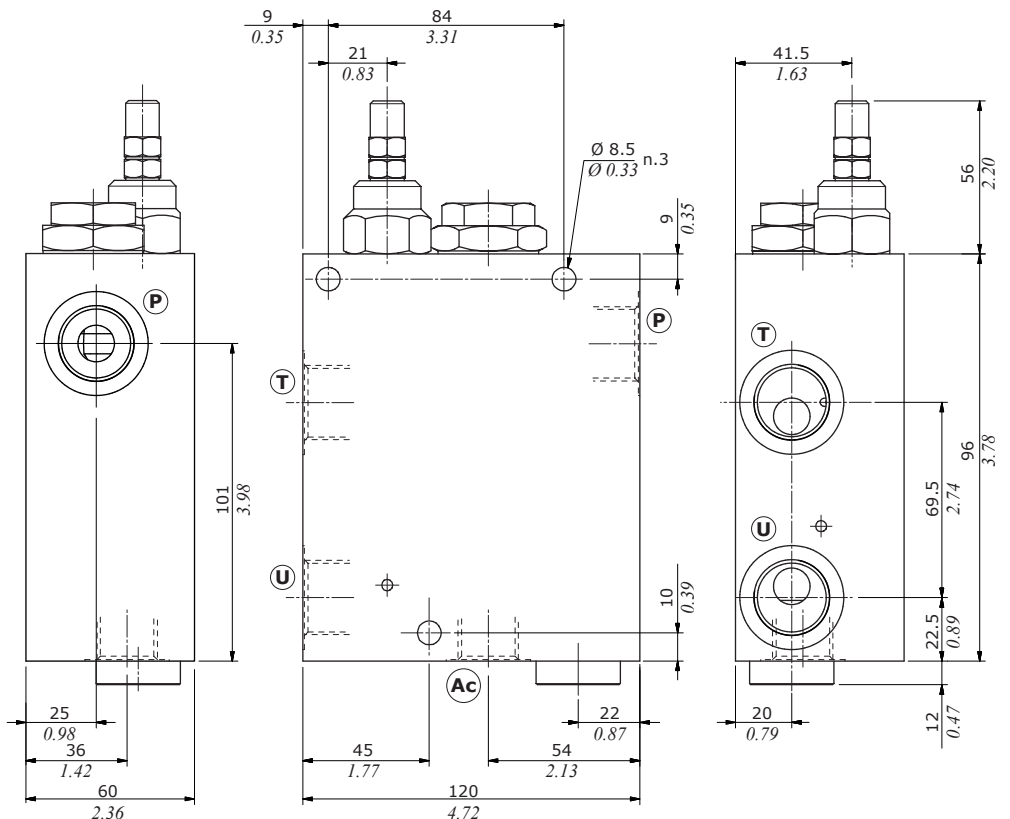

Ordering codes and description composition

Port size
VDA 38/TR.S.VRR
1

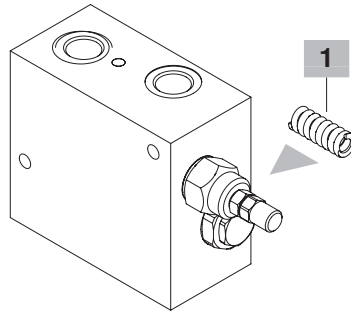

VDA complete valves

Single type valve configuration

Standard setting 200 bar at 5 l/min (2900 psi at 1.32 US gpm)

Standard differential pressure 15%

TYPE	CODE	DESCRIPTION
------	------	-------------

Configuration with G3/8 standard thread

VDA 38/TR.S.VRR	1210021101	Aluminium body, setting range 100-250 bar (1450-3600 psi)
VDA 38/DR/TR.S.VRR	1210021113	As previous one, with Drain port
VDA 38/TR.S.VRR/ac	1210022101	Steel body, setting range 100-250 bar (1450-3600 psi)

Configuration with G1/2 standard thread

VDA 12/TR.S.VRR	1210031101	Aluminium body, setting range 100-250 bar (1450-3600 psi)
VDA 12/DR/TR.S.VRR	1210031104	As previous one, with Drain port
VDA 12/TR.S.VRR/ac	1210032101	Steel body, setting range 100-250 bar (1450-3600 psi)

Configuration with G3/4 standard thread

VDA 34/TR.S.VRR	1210041101	Aluminium body, setting range 100-250 bar (1450-3600 psi)
VDA 34/DR/TR.S.VRR	1210041108	As previous one, with Drain port
VDA 34/TR.S.VRR/ac	1210042100	Steel body, setting range 100-250 bar (1450-3600 psi)

Configuration with SAE8 standard thread

VDA 38/TR.S.VRR/SAE	1210021200	Aluminium body, setting range 100-250 bar (1450-3600 psi)
----------------------------	------------	---

Configuration with SAE10 standard thread

VDA 12/TR.S.VRR/SAE	1210031200	Aluminium body, setting range 100-250 bar (1450-3600 psi)
VDA 12/TR.S.VRR/ac/SAE	1210032102	Steel body, setting range 100-250 bar (1450-3600 psi)

Configuration with SAE12 standard thread

VDA 34/TR.S.VRR/SAE	1210041200	Aluminium body, setting range 100-250 bar (1450-3600 psi)
VDA 34/TR.S.VRR/ac/SAE	1210042200	Steel body, setting range 100-250 bar (1450-3600 psi)

For other steel body configurations, SAE thread and configurations with FPM (Viton) seals, contact our Sales Dpt.

1 Pressure setting springs

TYPE	CODE	DESCRIPTION
TV	3ML1164000	Setting range 5-110 bar (72.5-1600 psi)
TR	3ML1164001	Setting range 100-250 bar (1450-3600 psi)

Rating diagrams

VDA 38 P→T pressure drop vs. flow

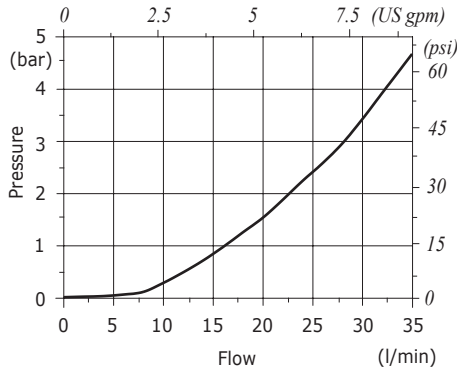

VDA 38 P→U pressure drop vs. flow

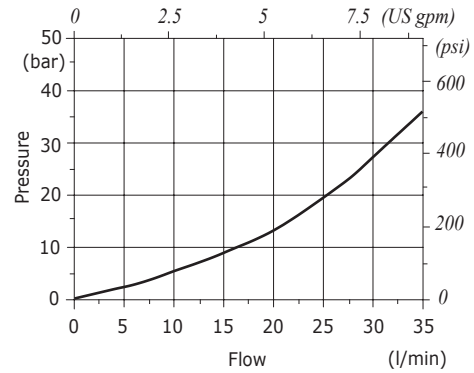

VDA 12 and VDA 12/DR pressure drop vs. flow

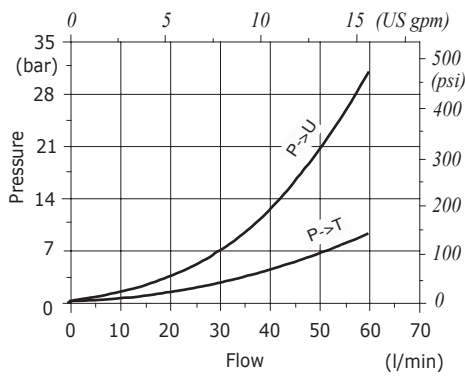

VDA 34 pressure drop vs. flow

