



Type VDA/FL unloader valves

- Face mounting cetop 3 (6-38) or cetop 5 (10-12)
- Built-in check

Technical specifications and diagrams are measured with mineral oil of 46 cSt viscosity at 40°C (104°F) temperature.

	VDA/FL 38	VDA/FL 12
Nominal flow	25 l/min (6.6 US gpm)	50 l/min (13.2 US gpm)
Max. pressure	Aluminium body = 210 bar (3050 psi) Steel body = 350 bar (5100 psi)	
Fluid	mineral based oil	
Viscosity	from 10 to 200 cSt	
Max. level of contamination	18/16/13 ISO4406	
Fluid temperature	with NBR seals from -20°C (-4°F) to 80°C (176°F)	
Environmental temp. for working conditions	from -40°C (-40°F) to 100°C (212°F)	
Weight	aluminium	2.43 kg (5.35 lb)
	steel	6 kg (13.23 lb)
		2.80 kg (6.17 lb)
		7.05 kg (15.54 lb)

NOTE - For different conditions, please contact Walvoil Sales Dpt.

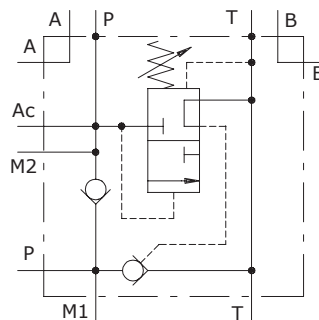

Ordering codes and description composition

Port size
VDA/FL 6-38/TR.S.VRR
1

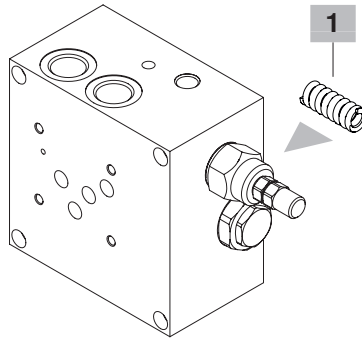

VDA/FL complete valves

Standard setting 200 bar (2900 psi) at 5 l/min (1.32 US gpm)

Standard differential pressure 15%

TYPE	CODE	DESCRIPTION
------	------	-------------

Configuration with G3/8 standard thread

VDA/FL 6-38/TR.S.VRR	1214021101	Aluminium body, range 100-250 bar (1450-3600 psi)
-----------------------------	------------	---

VDA/FL 6-38/TR.S.VRR/ac	1214022100	Steel body, as previous one
--------------------------------	------------	-----------------------------

Configuration with G1/2 standard thread

VDA/FL 10-12/TR.S.VRR	1214031101	Aluminium body, range 100-250 bar (1450-3600 psi)
------------------------------	------------	---

VDA/FL 10-12/TR.S.VRR/ac	1214032100	Steel body, as previous one
---------------------------------	------------	-----------------------------

For other steel body configurations, SAE thread and configurations with FPM (Viton) seals, contact our Sales Dpt.

1 Pressure setting springs

TYPE	CODE	DESCRIPTION
TV	3ML1164000	Setting range 5-110 bar (72.5-1600 psi)
TR	3ML1164001	Setting range 100-250 bar (1450-3600 psi)

Rating diagrams

VDA/FL 6-38 P→T pressure drop vs. flow

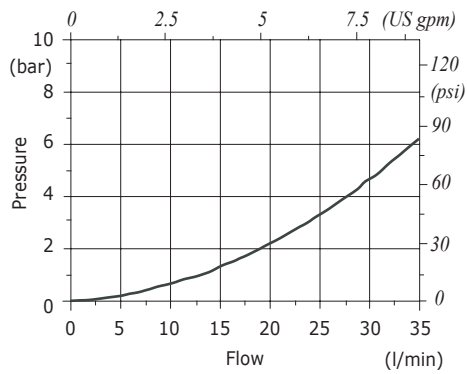

VDA/FL 6-38 P→P cetop pressure drop vs. flow

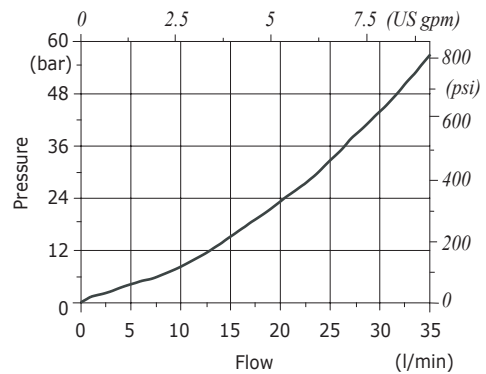

VDA/FL 10-12 P→T pressure drop vs. flow

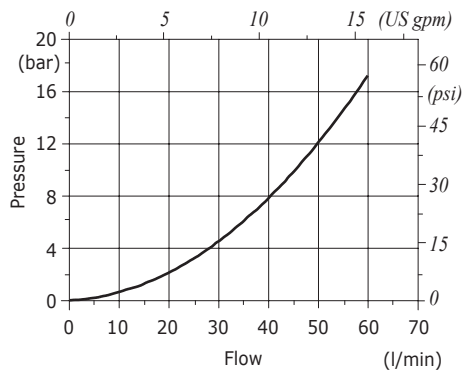

VDA/FL 10-12 P→P cetop pressure drop vs. flow

