



Type VEP/FL two pump "high-low" unloading valves

- Cetop 3 (6-38) - 5 (10-12) - 7 (16-34 and 16-100) flanging
- Flange assembling according to ISO 4401:2005 (CETOP)

Technical specifications and diagrams are measured with mineral oil of 46 cSt viscosity at 40°C (104°F) temperature.

Line	VEP/FL 6-38	VEP/FL 10-12	VEP/FL 16-34	VEP/FL 16-100	
Nominal flow	Ap (high pressure inlet port)	10 l/min (2.6 US gpm)	20 l/min (5.3 US gpm)	30 l/min (7.9 US gpm)	30 l/min (7.9 US gpm)
	Bp (low pressure inlet port)	25 l/min (6.6 US gpm)	45 l/min (11.9 US gpm)	80 l/min (21.1 US gpm)	80 l/min (21.1 US gpm)
	U (work port)	330 l/min (7.9 US gpm)	55 l/min (14.5 US gpm)	100 l/min (26.4 US gpm)	100 l/min (26.4 US gpm)
Max. pressure	Aluminium body = 210 bar (3050 psi) Steel body = 350 bar (5100 psi)				
Fluid	mineral based oil				
Viscosity	from 10 to 200 cSt				
Max. level of contamination	18/16/13 ISO4406				
Fluid temperature	with NBR seals from -20°C (-4°F) to 80°C (176°F)				
Environmental temp. for working conditions	from -40°C (-40°F) to 100°C (212°F)				
Weight	aluminium	1.56 kg (3.44 lb)	3.01 kg (6.63 lb)	7.05 kg (15.54 lb)	6.32 kg (13.93 lb)
	steel	3.58 kg (7.89 lb)	6.65 kg (14.66 lb)	17.58 kg (38.76 lb)	14.97 kg (33.00 lb)

NOTE - For different conditions, please contact Walvoil Sales Dpt.

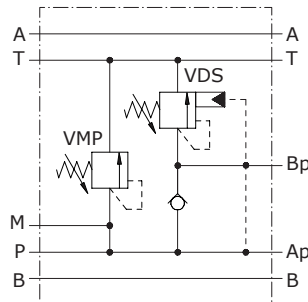

Dimensions

Dimensions are in mm-in

Valve type	A1	B1	ØY	C	D	E
VEP/FL 6-38	50	21.75	6,5	7	28.5	26.5
	1.97	0.86	0.25	0.27	1.12	1.04
VEP/FL 10-12	60	37	6.5	7	30	33
	2.36	1.46	0.25	0.27	1.18	1.30

Valve type	F	G	H	I	L	M1
VEP/FL 6-38	100	184.5	58	7	7	100
	3.94	7.26	2.28	0.27	0.27	3.94
VEP/FL 10-12	120	219	66	7	7	120
	4.72	8.62	2.60	0.27	0.27	4.72

Valve type	N	O	P	Q	R	S
VEP/FL 6-38	50	7	20	35	23	19
	1.97	0.27	0.79	1.38	0.91	0.75
VEP/FL 10-12	60	7	25	46	28	22
	2.36	0.27	0.98	1.81	1.10	0.87

Valve type	T1	U	V	W	X	X1	Z
VEP/FL 6-38	31	30	20	34	28	50	17
	1.22	1.18	0.79	1.34	1.10	1.97	0.67
VEP/FL 10-12	27	44	27	38	35	69	69
	1.06	1.73	1.06	1.50	1.38	2.71	2.71

Valve type	A-B	M	T	Ap	Bp
VEP/FL 6-38	G3/8	G1/4	G1/2	G1/4	G3/8
VEP/FL 10-12	G1/2	G1/4	G3/4	G3/8	G1/2

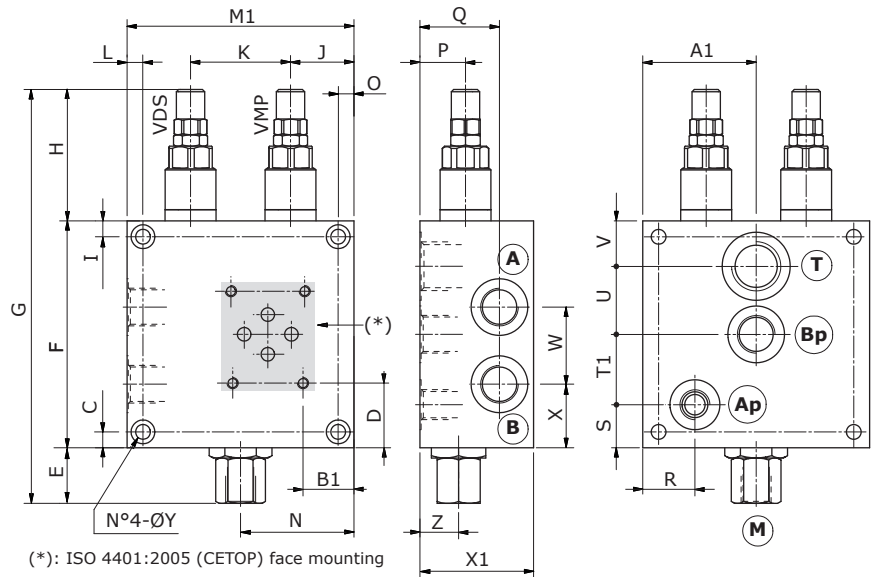

Valve type	A-B	M	T	Ap	Bp
VEP/FL 16-34	G3/4	G1/4	G1"	G1/2	G3/4

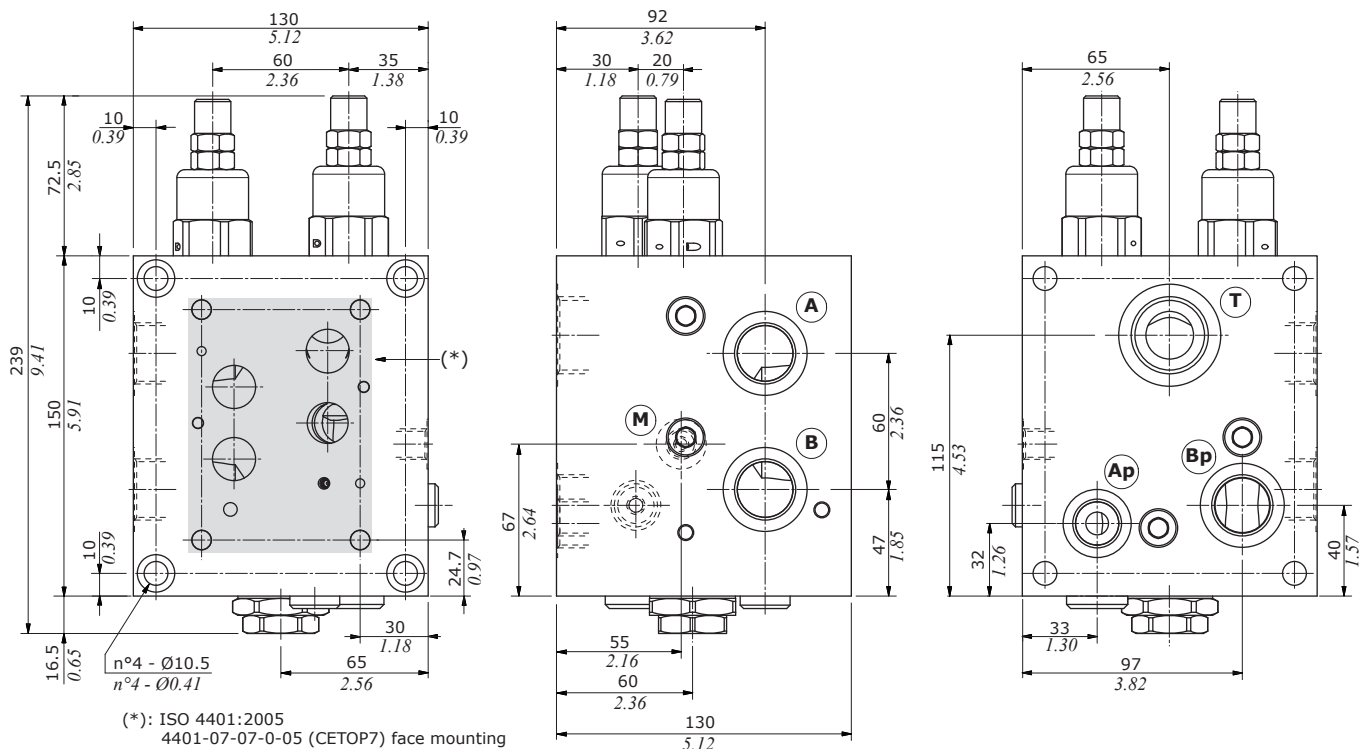

Logic valves

Two pump "hi-low" unloading-valves

VEP/FL

Dimensions

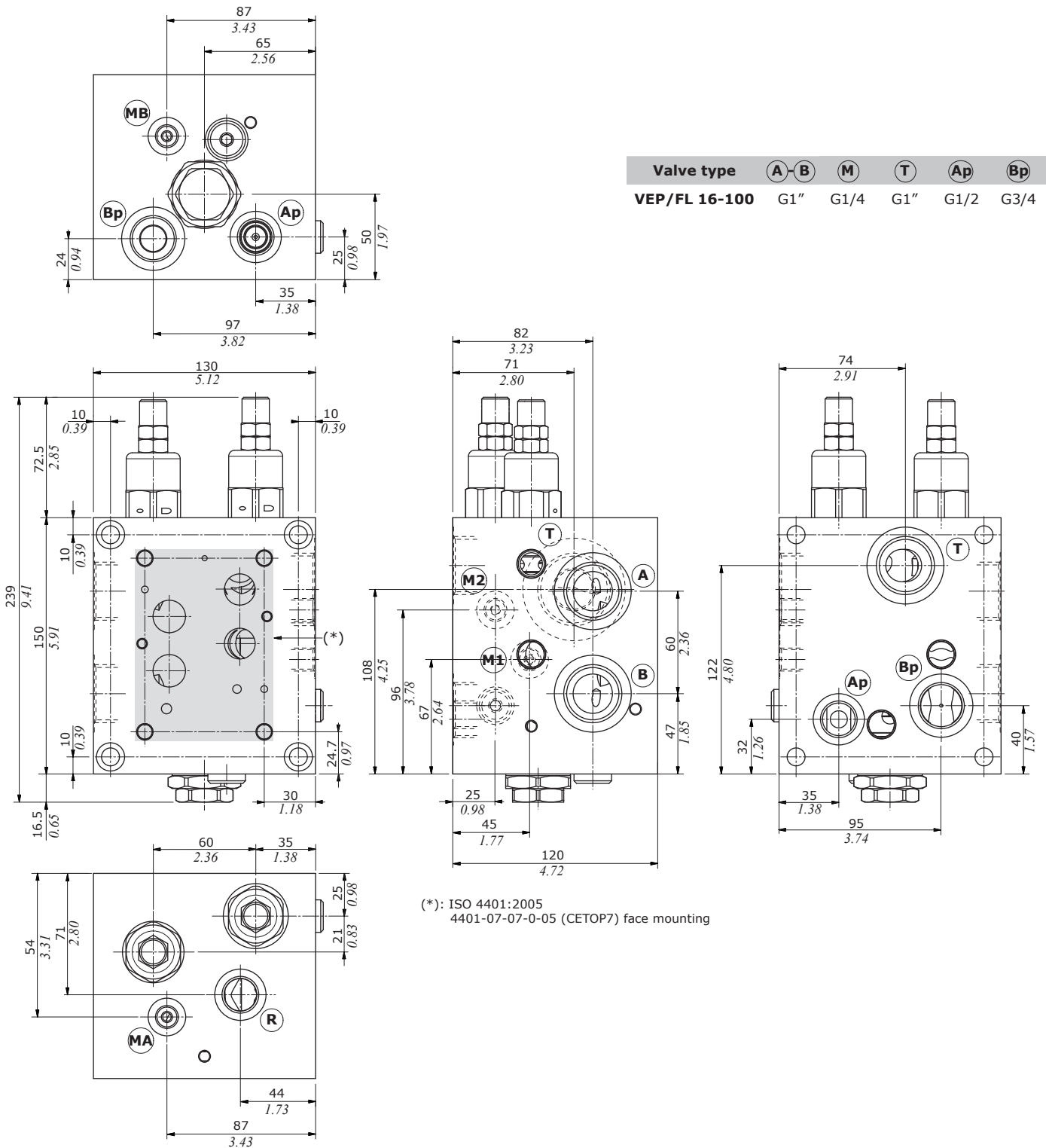

Ordering codes and description composition

Port size
VEP/FL 6-38/TR-TV.S

4 5

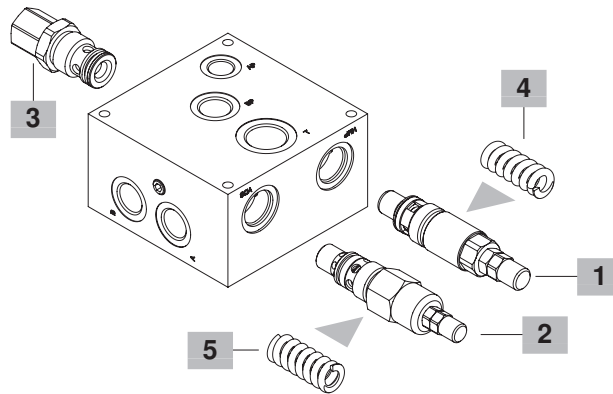

VEP/FL complete valves

Single type valve configuration

High pressure (Ap): range 180-350 bar (2600-5075 psi) and standard setting 280 bar (4060 psi) at 5 l/min (1.32 US gpm); Low Pressure (Bp): see below

Configuration with G3/8 standard thread

TYPE: **VEP/FL 6-38/TR-TV.S** CODE: 1224021101

DESCRIPTION: Aluminium body, Bp: range 20-80 bar (290-1160 psi), standard setting 60 bar (870 psi) at 5l/min (1.32 US gpm)

TYPE: **VEP/FL 6-38/TR-TV.S/ac** CODE: 1224022100

DESCRIPTION: Steel body, as previous one

Configuration with G1/2 standard thread

TYPE: **VEP/FL 10-12/TR-TV.S** CODE: 1224031101

DESCRIPTION: Aluminium body, Bp: range 5-80 bar (72.5-1160 psi), standard setting 40 bar (870 psi) at 5l/min (1.32 US gpm)

TYPE: **VEP/FL 10-12/TR-TV.S/ac** CODE: 1224032100

DESCRIPTION: Steel body, as previous one

Configuration with G3/4 standard thread

TYPE: **VEP/FL 16-34/TR-TV.S** CODE: 1224041101

DESCRIPTION: Aluminium body, Bp: range 10-80 bar (145-1160 psi), standard setting 50 bar (725 psi) at 5 l/min (1.32 US gpm)

TYPE: **VEP/FL 16-34/TR-TV.S/ac** CODE: 1224042101

DESCRIPTION: Steel body, as previous one

Configuration with G1" standard thread

TYPE: **VEP/FL 16-100/TR-TB.S** CODE: 1224041151

DESCRIPTION: Aluminium body, Bp: range 10-50 bar (290-1160 psi), standard setting 30 bar (870 psi) at 5l/min (1.32 US gpm)

TYPE: **VEP/FL 16-100/TR-TB.S/ac** CODE: 1224042150

DESCRIPTION: Steel body, as previous one

For other steel body configurations, SAE threads and configurations with FPM (Viton) seals, please contact our Sales Dpt.

1 Direct acting pressure relief valve

Standard setting 160 bar at 5 l/min (2320 psi at 1.32 US gpm)

TYPE	CODE	DESCRIPTION
------	------	-------------

For G3/8 port configuration valve

VMP 5/TR.S 1100520401 Setting range 50-220 bar (725-3200 psi) (Ap)

For VEP 10-12 and VEP 16-34 valves

VMP 10/TR.S 1100530401 Setting range 50-220 bar (725-3200 psi) (Ap)

For VEP 16-100 valve

VMP 20/TR.S 1100540403 Setting range 50-220 bar (725-3200 psi) (Ap)

2 Sequence valve

Sequence cartridge setting range 20-80 bar (290-1150 psi) (Lp)

Standard setting 160 bar at 5 l/min (2320 psi at 1.32 US gpm)

TYPE	CODE	DESCRIPTION
------	------	-------------

VDS/VEP 38/TV.S 1205020400 For G3/8 port configuration

VDS/VEP 12/TV.S 1205030400 For G1/2 port configuration

VDS/VEP 34/TV.S 1205040405 For G3/4 port configuration

VDS/VEP 34/TB.S 1205040401 For G1" port configuration

3 Check valves

Opening pressure 0.5 bar

TYPE	CODE	DESCRIPTION
------	------	-------------

VUI 38/Pa0,5.man 1300020413 For G3/8 port configuration

VUI 12/Pa0,5 pass.magg.man 1300030402 For G1/2 port configuration

VUI 34/Pa0,5 pass.magg 1300040401 For G3/4 and G1" port configuration

4 Pressure relief valve setting springs

TYPE	CODE	DESCRIPTION
------	------	-------------

For VMP 5 valve on VEP/FL 6-38 complete valve (Ap)

TS 3MOL315330 Setting range 50-220 bar (725-3200 psi)

TR 3ML1143600 Setting range 180-350 bar (2600-5100 psi)

For VMP 10 valve on VEP/FL 10-12 complete valve (Ap)

TS 3MOL317420 Setting range 50-220 bar (725-3200 psi)

TR 3MOL317440 Setting range 180-350 bar (2600-5100 psi)

For VMP 20 valve on VEP/FL 16-34 and 16-100 complete valves (Ap)

TS 3ML1204200 Setting range 50-220 bar (725-3200 psi)

TR 3ML1214500 Setting range 180-350 bar (2600-5100 psi)

5 Sequence valve setting springs

TYPE	CODE	DESCRIPTION
------	------	-------------

For VDS/VEP 38 valve on VEP/FL 6-38 complete valve (Bp)

TB 3MOL314311 Setting range 5-40 bar (72.5-580 psi)

TV 3MOL314330 Setting range 20-80 bar (290-1150 psi)

For VDS/VEP 12 valve on VEP/FL 10-12 complete valve (Bp)

TV 3MOL317420 Setting range 5-80 bar (72.5-1150 psi)

For VDS/VEP 34 valve on VEP/FL 16-34 and 16-100 complete valves (Bp)

TB 3ML1174500 Setting range 10-50 bar (145-725 psi)

TV 3ML1204200 Setting range 10-80 bar (145-1150 psi)

VEP/FL 6-38 pressure drop vs. flow from Bp→T and Bp→U

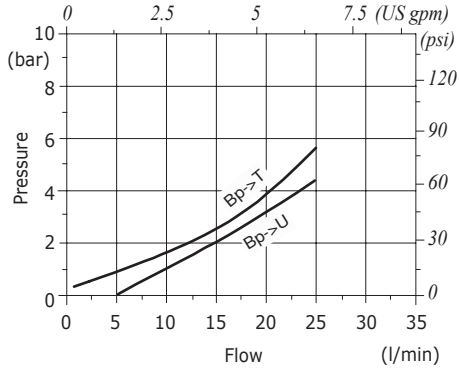

VEP/FL 6-38: VMP setting example at 5 l/min (1.32 US gpm)

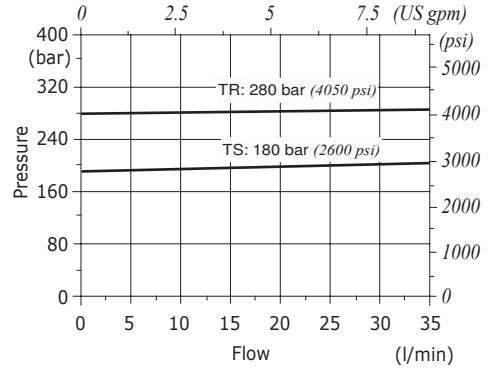

VEP/FL 10-12 pressure drop vs. flow from Bp→T and Bp→U

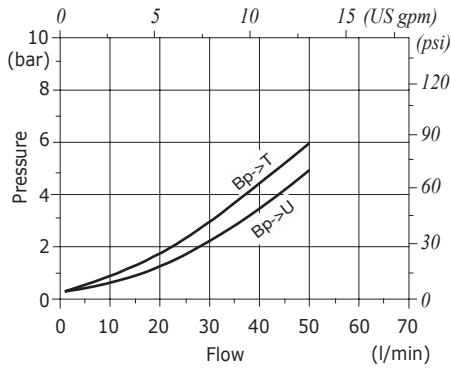

VEP/FL 10-12: VMP setting example at 5 l/min (1.32 US gpm)

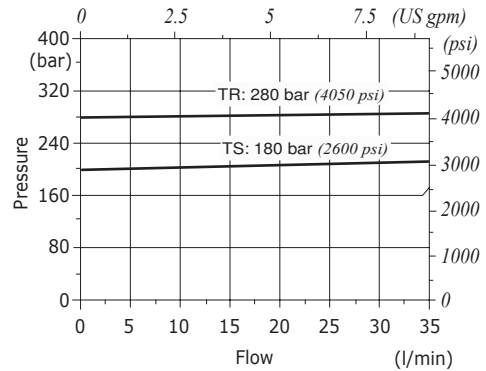

VEP/FL 16-34 pressure drop vs. flow from Bp→T and Bp→U

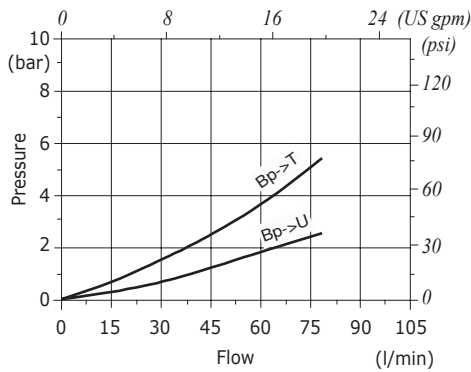

VEP/FL 100 pressure drop vs. flow from Bp→T and Bp→U

