



**RECOMMANDATIONS**

**Fluid:** best use mineral oil with viscosity ranging between 10 and 200 cSt.

**Filter:** see page Z.9000.000.

**Weight:**

- 0,45 kg aluminium valves
- 0,9 kg steel valves

**Material:** internal components made out of high grade steel duly treated and fabricated.

For more information please ask our technical office .

Variations and modifications of technical features and dimensions are reserved. **OLEOSTAR S.p.A.** also reserves the right to stop production of each and any model listed in the catalogue with no notice.

Copyrights on the text contained herein belong to **OLEOSTAR S.p.A.** . Partial and full reproductions or copies of this catalogue are forbidden.

**• RATING DIAGRAMS**

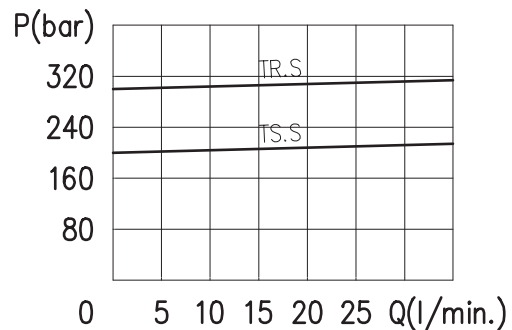
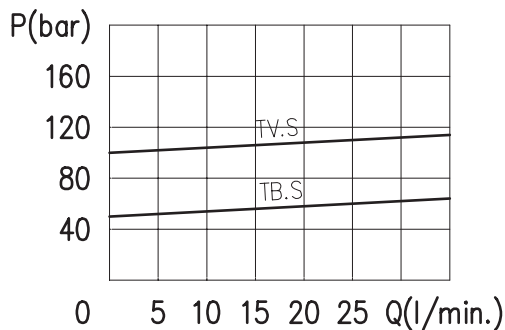

Oil viscosity 46 cSt

**• ADJUSTMENTS**

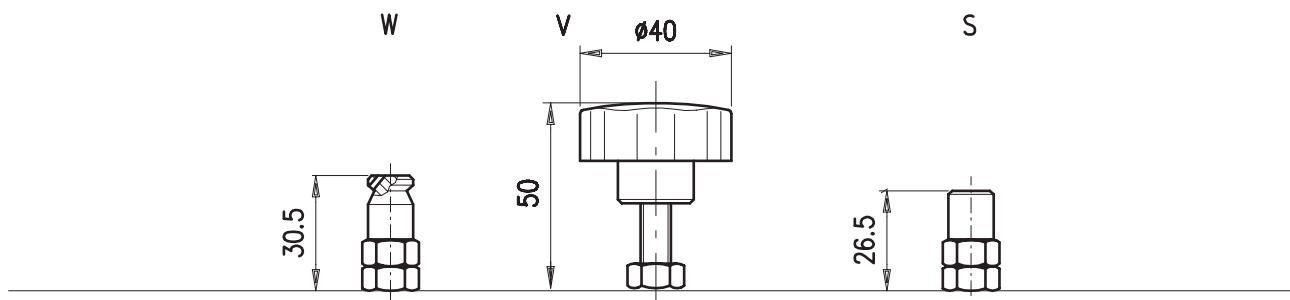

**• CODE NUMBER**

**VAIF 5Y /D1S/ 12/ OMR / □□ . □ / □□**

